

FIDELITY VOLT

DH 1/5 4WD REAR STRAIGHT BRIDGE DESERT TRUCK

User Manual



OFFROAD
4-WHEEL DRIVE

Upgrades

This is our latest Voltz version. It has following upgrades as against previous version:

- Hydraulic braking system (optional) support added
- 12S system support (HobbyWing Max4 Combo or equivalent recommended)
- New wheel hub assembly
- Brake disc added
- Rear shock structure enhanced
- Shock body in alloy 7075
- Front hinge arm pin thickened Electronic Speed Controller Motor Switch Receiver Battery Battery to 7mm dia.
- Swaybar redesigned and thickened to 5mm dia.
- Towhook mount added
- New wheel
- New electronic mount plate
- New shell design

Cautions



Failure to follow these instructions would damage your kit, and even cause serious bodily injury or even death.

Voltz is an off-road racing car, so its structure like shocks, gearing etc is designed to race and jump in outdoor and offroad field. It is a full upgraded metallic car, weighing 27kg with batteries. Driving inside a building or in a crowded place is dangerous.

Before Running

- Read manual under the guidance of a parent, guardian or a responsible adult if possible.

While Operating

- Do not run in public street, which could cause serious accidents, personal injuries and property damages.
- Do not run near pedestrians or small children.
- Do not run in small or confined areas.
- **Do not keep doing small circles or ballet turns at high speed which will cause damage to gears.**
- **Do not give full throttle at startup frequently which may cause damage to gears.**

Before Operating

- Make sure that all screws and nuts are properly tightened.
- Always use fresh batteries for your transmitter and receiver to avoid losing control the model.
- Always check the position of throttle trigger and make sure it is in Neutral.

After Running

- Turn off receiver first, then off transmitter, to prevent the car from losing control.
- Perform maintenance regularly like doing for a real car.
- Failure to do this can result in increased wear and damage to the engine and chassis.
- **Be careful when taking off bolts. Thread Lockers are applied in key parts like diff, gearbox, axle and shaft. Do NOT force the fittings out. Heat it and then remove it.**

Battery Safety

- Be careful when handling the battery. It will be hot after running. Frayed wire might result in short circuit which possibly causes fire.

Contents

Upgrades	1
Cautions	1
Motor & ESC Connection	3
Connection	3
ESC Setup	3
Set up the throttle range.....	3
Power on/off and beep instructions	4
Programmable Items.....	5
Programming method.....	6
Factory reset.....	6
Explanation for LED status.....	6
Trouble Shooting.....	7
Frontend Assembly	8
Central Gearbox & Differential Assembly	9
Chassis & Steering System Assembly	10
Battery Box Assembly	11
Hydraulic Braking System Assembly	12
Rear Solid Axle Assembly	13
Rear Assembly	14
Wheel Assembly	15
Roll Cage Assembly	16
Shell Assembly	17
Roll Cage Installation	18
Wheel Installation	19
Assembly List	20
Part List	20

Motor & ESC Connection

Connection

Voltz RTR version comes with HobbyWing Max4 Combo (**EzRun Max4 HV ESC** and **EzRun 70125SD-560KV Motor**). Below instructions are made according to this configuration. If you plan to use a different power configuration, the connection and setup might be different. Please consult your dealer and follow the instructions accordingly.

Note: Following diagram and instructions are copied from HobbyWing documentation. Reading original version, please download the manuals from HobbyWing website or request it from your dealer.

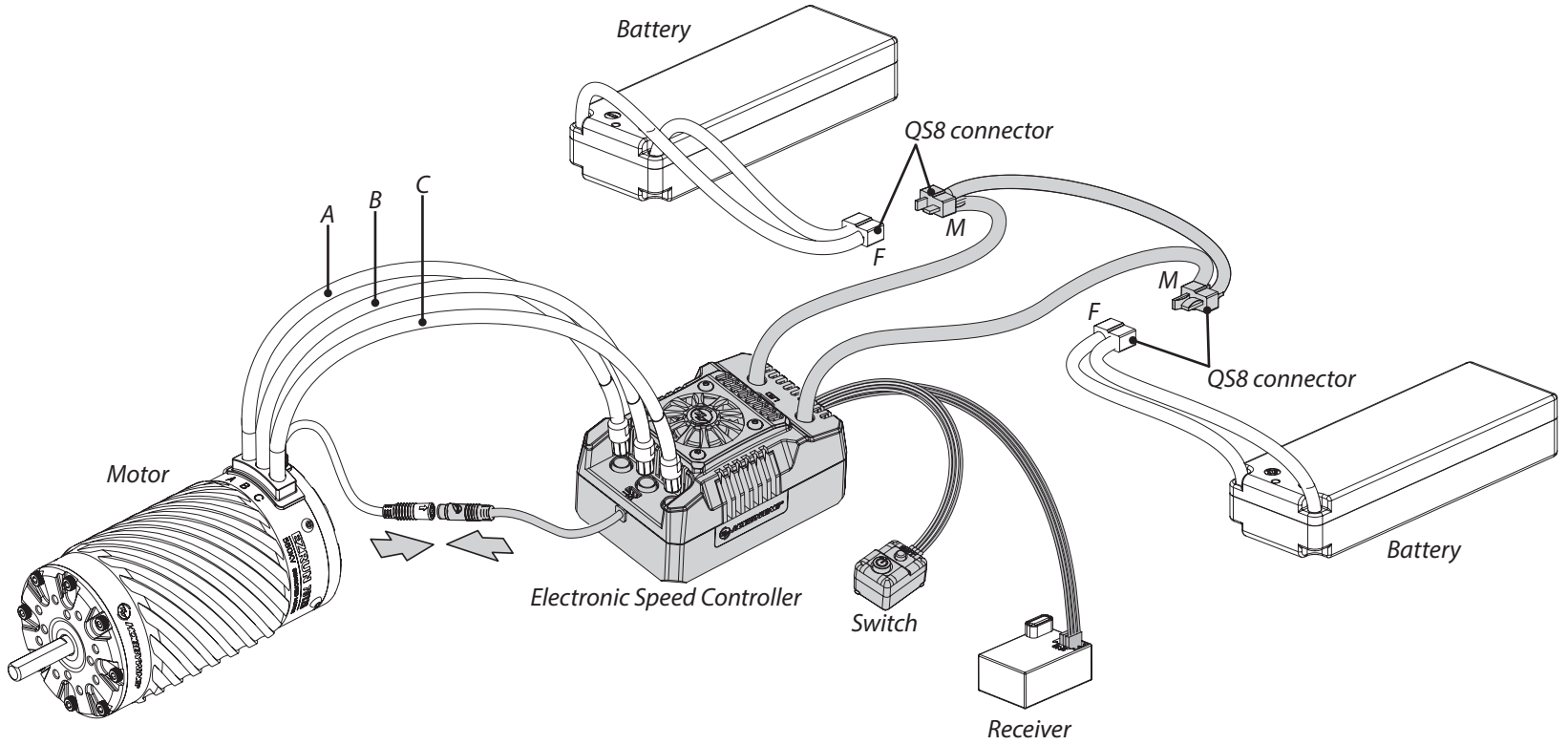

- When connecting the motor and esc, please pay attention to the marked three-phase position of A, B and C to ensure that the three wires of the motor and esc are connected correspondingly. Otherwise, it cannot run normally and even damage the esc and motor.



That is: Wire A of the esc matches wire A of the motor, wire B of the esc matches wire B of the motor, wire C of the esc matches wire C of the motor.

- When the sensor wire of the motor is connected with the sensor wire of the esc, it shall be connected correspondingly according to the arrow mark on the sensor interface.



Inspection: Before power on the esc, please check the reliability of the motor installation and the correctness of all connections.

ESC Setup

Set up the throttle range

Note: Following diagram and instructions are copied from HobbyWing documentation. Reading original version, please download the manuals from HobbyWing website.

When first use the ESC or the transmitter changes "TRIM" tune, D/R, EPA and other parameters, the throttle range is need to reset. We strongly recommend to open the fail safe function of the transmitter, set the no signal protection of throttle channel ("F/S") to close the output or set the protection value to the throttle neutral position. Thus the motor can stop running if the receiver cannot

Hold the SET button

Press the ON/OFF button

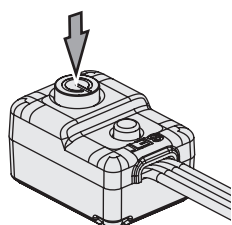
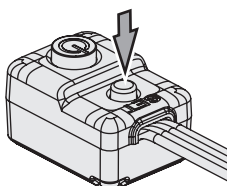

Release the SET button once the LED flashes.

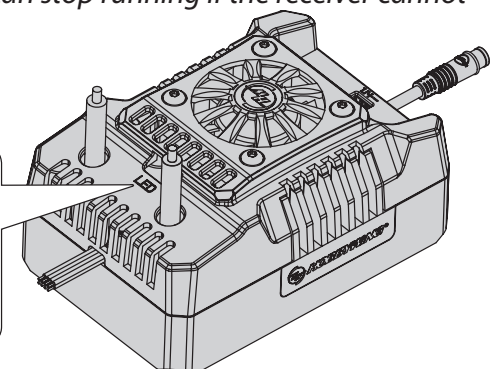

receive the signal of the transmitter. The calibrating steps of throttle is as follows:

1. Turn on the transmitter, ensure all parameters (D/R, EPA, ATL) on the throttle channel are at default (100%). For transmitter without LCD, please turn the knob to the maximum, and the throttle "TRIM" to 0. (If the transmitter without LCD, turn the knob to the middle point).
2. Start by turning on the transmitter with the ESC turned off but connected to a battery. Holding the "SET" button then press the "ON/OFF" button, the RED LED on the ESC starts to flash (The motor beeps at the same time), and then release the "SET" button immediately.

Note: Beeps from the motor may be low sometimes, and you can check the LED status instead.

A Move the throttle trigger to the neutral position and press the SET button.

The Green LED flashes once and motor emits "Beep" tone.

B Move the throttle trigger to the end position of forward and press the SET button.

The Green LED flashes twice and motor emits "Beep-Beep" tone.

C Move the throttle trigger to the end position of backward and press the SET button.

The Green LED flashes three times and motor emits "Beep-Beep-Beep" tone.

3. Set the neutral point, the full throttle endpoint and the full brake endpoint.
 - a. Leave transmitter at the neutral position, press the "SET" button, the RED LED dies out and the GREEN LED flashes 1 time and the motor beeps 1 time to accept the neutral position.
 - b. Pull the throttle trigger to the full throttle position, press the "SET" button, the GREEN LED blinks 2 times and the motor beeps 2 times to accept the full throttle endpoint.
 - c. Push the throttle trigger to the full brake position, press the "SET" button, the GREEN LED blinks 3 times and the motor beeps 3 times to accept the full brake endpoint.

- Note:**
- **The end position of forward:** Pull the trigger to the maximum throttle position if it is pistol-style transmitter. Push the throttle to the top if it is board-style transmitter.
 - **The end position of backward:** Push the trigger to the maximum brake position if it is pistol-style transmitter. Push the throttle to the bottom if it is board-style transmitter.
4. The motor can be started after the ESC/Radio calibration is complete.

Power on/off and beep instructions

Switch instructions: short press ON/OFF key to power-on, long press on ON/OFF key to shut down.

Power-on beep description: Under normal circumstances, the ESC will emit a few "beep" to indicate the number of lithium cells. A short "beep-" means the #1, and a long "beep—" means the #5. For example: "beep—, beep—" means 6 cells, "beep—, beep-beep—" means 7 cells, "beep—beep—" means 10 cells, "beep—beep—, beep-beep—" means 12 cells.

Note: Motor beeping at the same time, the ESC light flashes synchronously. For example: when the motor makes a long beep, the esc flashes for a long time, and when the motor makes a short beep, the esc flashes for a short time.

Programmable Items

The column of white words on black background in the following table are the default values of programmable items.

Item	Opt. 1	Opt. 2	Opt. 3	Opt. 4	Opt. 5	Opt. 6	Opt. 7	Opt. 8	Opt. 9
Running mode	Forward with brake	Forward / Reverse with Brake	Forward with reverse						
Lipo Cells	Auto	6S	7S	8S	9S	10S	11S	12S	
Cutoff Voltage	Disabled	Auto (low)	Auto (medium)	Auto (high)					
Motor Rotation	CCW	CW							
BEC Voltage	6.0V	7.4V	8.4V						
Max. Brake Force	12.50%	25%	37.50%	50%	62.50%	75%	87.50%	100%	Disabled
Max. Reverse Force	25%	50%	75%	100%					
Punch	Level 1	Level 2	Level 3	Level 4	Level 5	Level 6	Level 7	Level 8	Level 9
Drag Brake Force	0%	5%	10%	20%	40%	60%	80%	100%	

1. Running Mode:

Option 1: Forward with brake

The vehicle can only move forward and has brake function. This is also commonly acceptable at races.

Option 2: Forward/Reverse and Brake

This option is known to be the "training" mode with "Forward/Reverse with Brake" function. The vehicle only brakes on the first time you push the throttle trigger to the reverse/brake zone. If the motor stops when the throttle trigger return to the neutral zone and then re-push the trigger to reverse zone, the vehicle will reverse, if the motor does not completely stop, then your vehicle won't reverse but still brake, you need to return the throttle trigger to the neutral zone and push it to reverse zone again. This method is for preventing vehicle from being accidentally reversed.

Option 3: Forward and Reverse

When the throttle trigger is pushed from neutral to reverse point, the motor reverses. This mode is generally used in special vehicles.

2. Lipo Cells:

Set the correct value according to the actual number of Lipo batteries used. The default is automatically calculated, and the "Auto" only recognizes the even number of Lipo batteries, such as 6S / 8S / 10S / 12S; The odd number of Lipo batteries, such as 7S/9S/11S, will not be recognized. This is to avoid mis-calculation during actual use, for example, 7S Lipo without power may be incorrectly calculated as fully charged 6S Lipo. Therefore, this parameter value needs to be manually set when using odd number of Lipo batteries.

3. Low Voltage Cut-Off:

This function is mainly to prevent excessive discharge of lithium batteries causing damage. The ESC monitors the battery voltage at all times, and once the voltage falls below the set threshold, the power output is reduced and the power output is completely cut off after a few seconds. When the voltage protection is entered, the red LED flashes in the "-", "-", "-". The three levels of low, medium and high here correspond to 2.8V/Cell, 3.1V/Cell and 3.4V/Cell respectively. For NiMH batteries, it is recommended to set this parameter to "Disabled".

4. Motor Rotation:

Setting the rotation of the motor. Due to some differences with the drivetrains on different car kits, it is possible to that the car will go in the opposite direction upon full throttle. In the event that this happens, you can set the "motor rotation direction" to the opposite direction; "CW" or "CCW".

5. BEC Voltage:

BEC voltage support 6V/7.4V/8.4V. Generally, 6.0V is suitable for standard servos, while 7.4V/8.4V is suitable for high-voltage servos. Please set according to the servo specifications.

WARNING! Do not set the BEC voltage above the maximum operating voltage of the servo, as this may damage the servo or even the ESC.

6. Max. Brake Force:

This ESC provides proportional braking function; the braking effect is decided by the position of the throttle trigger. It sets the percentage of available braking power when full brake is applied. Large amount will shorten the braking time but it may damage your pinion and spur gear.

7. Max. Reverse Force:

Refers to the reversing speed. Selecting different parameter values can produce different reversing speed. It is recommended to use a smaller reversing speed to avoid errors caused by reversing too quickly.

8. Punch:

Set in 1-9 stages, the higher the set value, the faster the acceleration. Kindly take into consideration according to the site, tire grip characteristics, vehicle configuration, etc. An aggressive setting may cause the tire to slip, the starting current to be too large and adversely affect the electronics performance.

9. Drag Brake:

Refers to the brake force generated by the motor when the throttle trigger returns to neutral position. Choose the appropriate value according to the type of vehicle, configuration, site, etc.

Programming method

1. The LED program card is used to set the parameters:

Connect the program card to the ESC and power up. Using the "ITEM" and "VALUE" buttons on the program card to quickly select and change the values. Press "OK" to save the parameters.

2. Use LCD program box to set parameters:

This ESC allows LCD program box to set parameters or LCD program box connecting to the computer to set parameters and update firmware (Use HOBBYWING USB LINK software). You need to connect your ESC and the LCD program box via a cable with two JR male connectors and turn on the ESC, after a few seconds, the esc will establish communication with the LCD program box, and then press any key on the program box to enter the parameter interface. You can adjust the setting via "ITEM" & "VALUE" buttons, and press the "OK (R/P)" button to save new settings to your ESC.

3. Use OTA Programmer to set parameters:

Connecting the OTA Bluetooth module to the programming port / fan port of the ESC, then use mobile phone to install HOBBYWING HW LINK App to set parameters or update firmware.

4. Data Logging

Connecting the OTA Bluetooth module to the ESC and establishing communication, you can view the real-time data in running and historical record data (graph) in the [Data Log] menu in HW link app.

Factory reset

Below are several ways to recover factory parameters:

1). The SET button:

When the throttle trigger is in the neutral position, press and hold the SET button continuously for about 8 seconds, the red and green lights will flash at the same time, indicating that the factory reset is successful and needs to be re-powered before it can be run.

2). The LED program card:

Once the LED program card is connected to the ESC, press the "RESET" key and then press "OK" to save to restore the factory settings.

3). The LCD program box:

Once the LCD program box is connected to the ESC, the "Restore Default" item is selected by the ITEM option and saved by pressing the OK (R/P) button to restore to the factory settings.

4). The OTA Bluetooth module:

After the OTA module is connected, go to the Parameter Settings and click the "Reset" button to restore to the factory settings.

Explanation for LED status

1. The run status indication:

- The throttle trigger is in the neutral point and the LED lights are off.
- When advancing, the red light is constantly on, and when the throttle is at full throttle, the green light is on.
- When reversing, the red light is constantly on; If the reversing force is set to 100%, the green light is also lit when the throttle is at the maximum of the reverse.

2. What the LED means when the relevant protection function is triggered:

- The red light flashes (single flash, "◊, ◊, ◊"): enters the low voltage protection state.
- The green light flashes (single flash, "◊, ◊, ◊"): enters the esc overheat protection state.
- The green light flashes (double flash, "◊◊, ◊◊, ◊◊"): enters the motor overheat protection state.

Note: Motor overheat protection is effective only when Hobbywing matching motor (such as EZRUN-70125SD) is used. When non Hobbywing matching motor is used, there is no motor overheat protection function.

- The green light flashes (three flashes, "◊◊◊, ◊◊◊, ◊◊◊"): enters the current protection state.
- The green light flashes (five flashes, "◊◊◊◊◊, ◊◊◊◊◊, ◊◊◊◊◊"): enters the capacitor overheat protection state.

Trouble Shooting

Troubles	Possible Causes	Solution
The light does not turn on after power-up, the motor does not start, and the fan does not work.	<ol style="list-style-type: none"> 1. The battery voltage is not output to the ESC; 2. The switch is damaged. 	<ol style="list-style-type: none"> 1. Check the battery, and whether the connection between battery and esc is good and whether the plug is soldered well; 2. Replace the switch.
The motor does not start after power-up, with a "beep-beep-, beep-beep-" warning tone accompanied by a flashing red light (approximately 0.5 seconds for each set of two-tone intervals).	The battery pack voltage is not within the range of support.	Check the battery voltage or change the battery for test.
After power on, the red light flashes quickly.	<ol style="list-style-type: none"> 1. The throttle signal is not detected by the ESC; 2. The neutral point of the ESC is not calibrated correctly. 	<ol style="list-style-type: none"> 1. Check if the throttle wire is plugged into the correct channel. Check if your transmitter is turned on. Check if the receiver ok. 2. Recalibrate the throttle travel.
The car is going in the reversed direction when the forward throttle is applied.	The transmission on the car kit is different	Set the parameter item "Motor Rotation" to the opposite direction.
The motor suddenly stopped or significantly reduced the output in running.	<ol style="list-style-type: none"> 1. Possible interference; 2. The ESC enters into low-voltage protection state; 3. The ESC enters into over-heat protection state. 	<ol style="list-style-type: none"> 1. Check the cause of the interference in the receiver and check the battery level of the transmitter; 2. Replace the battery if red light keeps flashing; 3. The green light continues to flash for temperature protection, please continue to use after the ESC or motor temperature is reduced (it is recommended to reduce the load on the vehicle).
The motor stuttered and unable to start.	<ol style="list-style-type: none"> 1. The motor is connected incorrectly; 2. ESC fault (partial power pipe MOSFET burned out). 	<ol style="list-style-type: none"> 1. Check the plugs and the solder points and whether the sequence of A, B and C wires is correct.; 2. Contact the dealer to handle the repair.
Going forward normally, but not reverse.	<ol style="list-style-type: none"> 1. The neutral point of the remote control throttle channel deviates from the brake area; 2. The parameter item "Runnig Mode" is set incorrectly; 3. The ESC is damaged. 	<ol style="list-style-type: none"> 1. Recalibrate the esc, when the throttle trigger is at the neutral point, the esc lights are off; 2. The parameter item "Runnig Mode" is set to incorrectly; 3. Contact the distributor to handle the repair.
LED displays three end horizontal lines all the time — — — when connecting LED program card; Or displays "Connecting ESC" when connecting LCD program box.	The program box is connected incorrectly to the ESC.	Connect the program box with the correct interface, which to the fan port.
The throttle travel setting could not be completed.	The ESC did not receive the correct throttle signal.	<ol style="list-style-type: none"> 1. Check whether the throttle cable is correctly connected to the receiver. 2. If the servo works normally, you can connect the throttle cable of esc to the steering channel to have a test, or change the transmitter/receiver system for test directly.

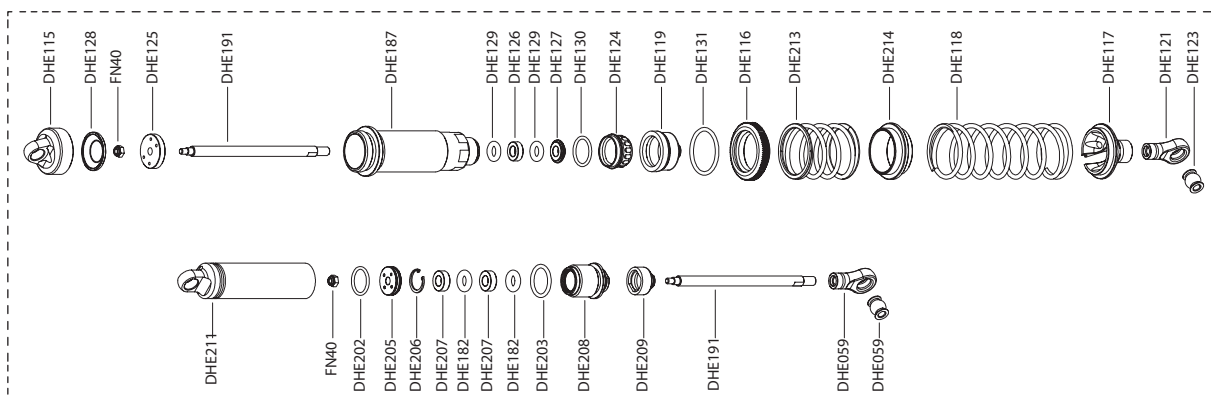
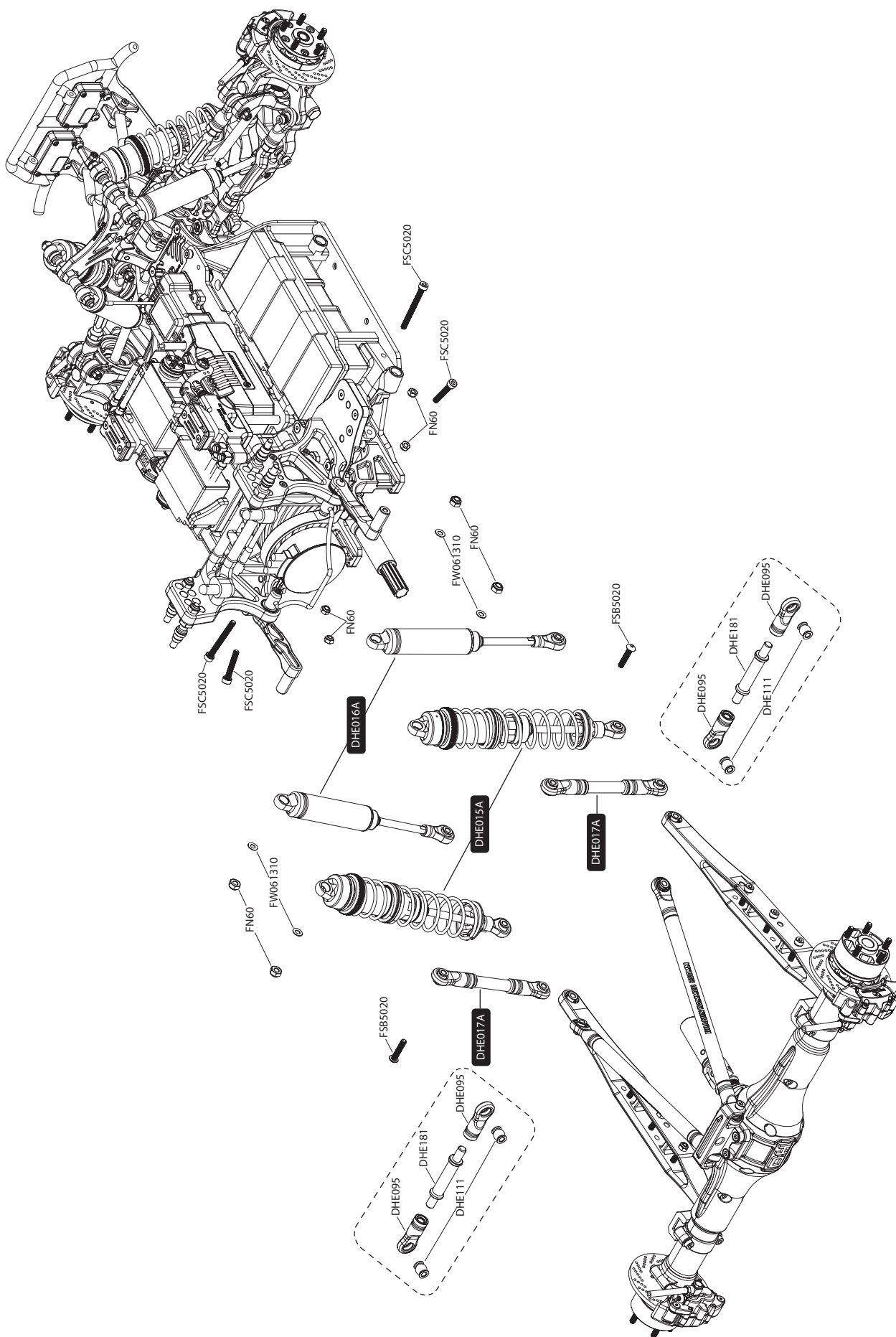

Wheel Assembly

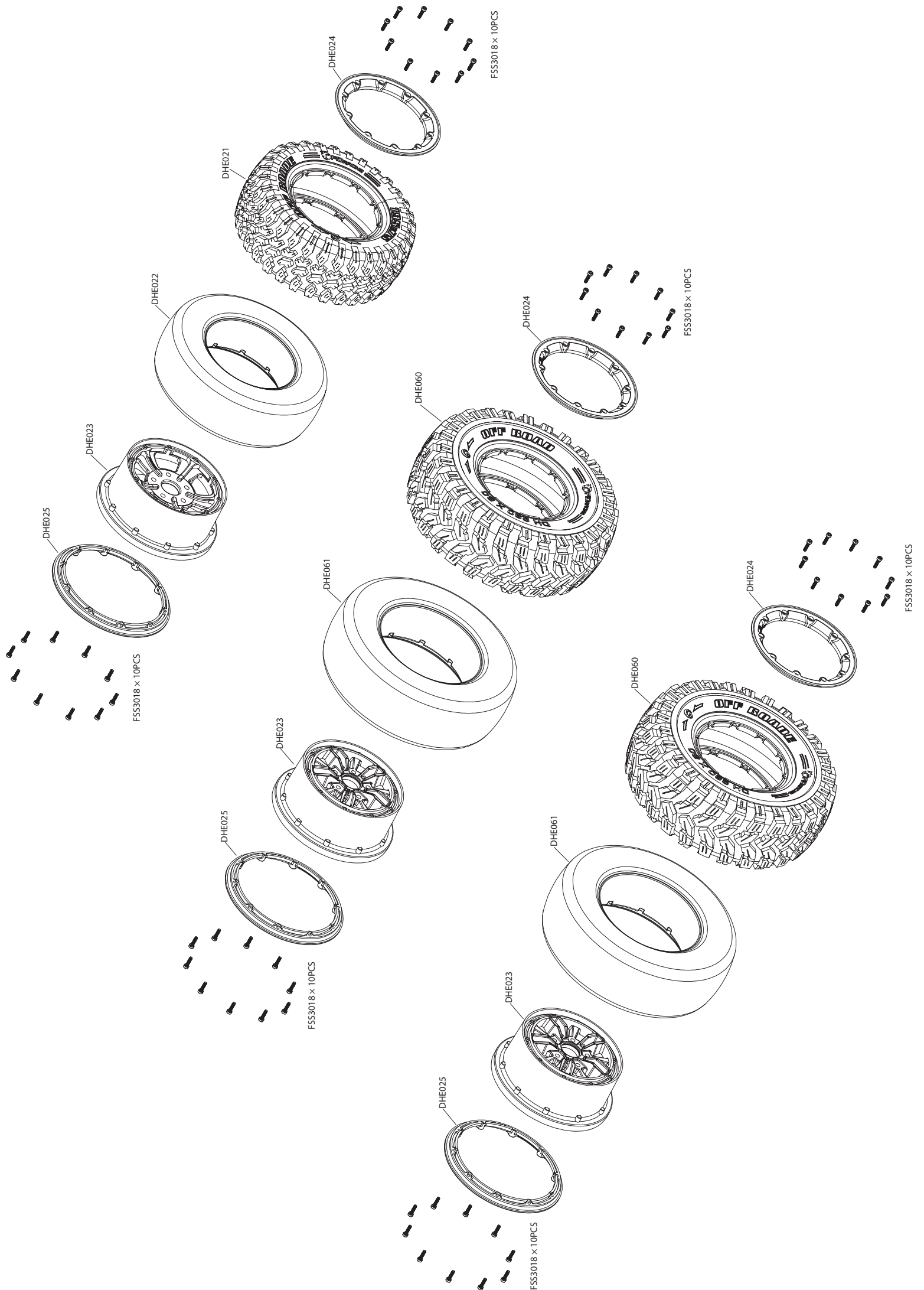

Shell Assembly

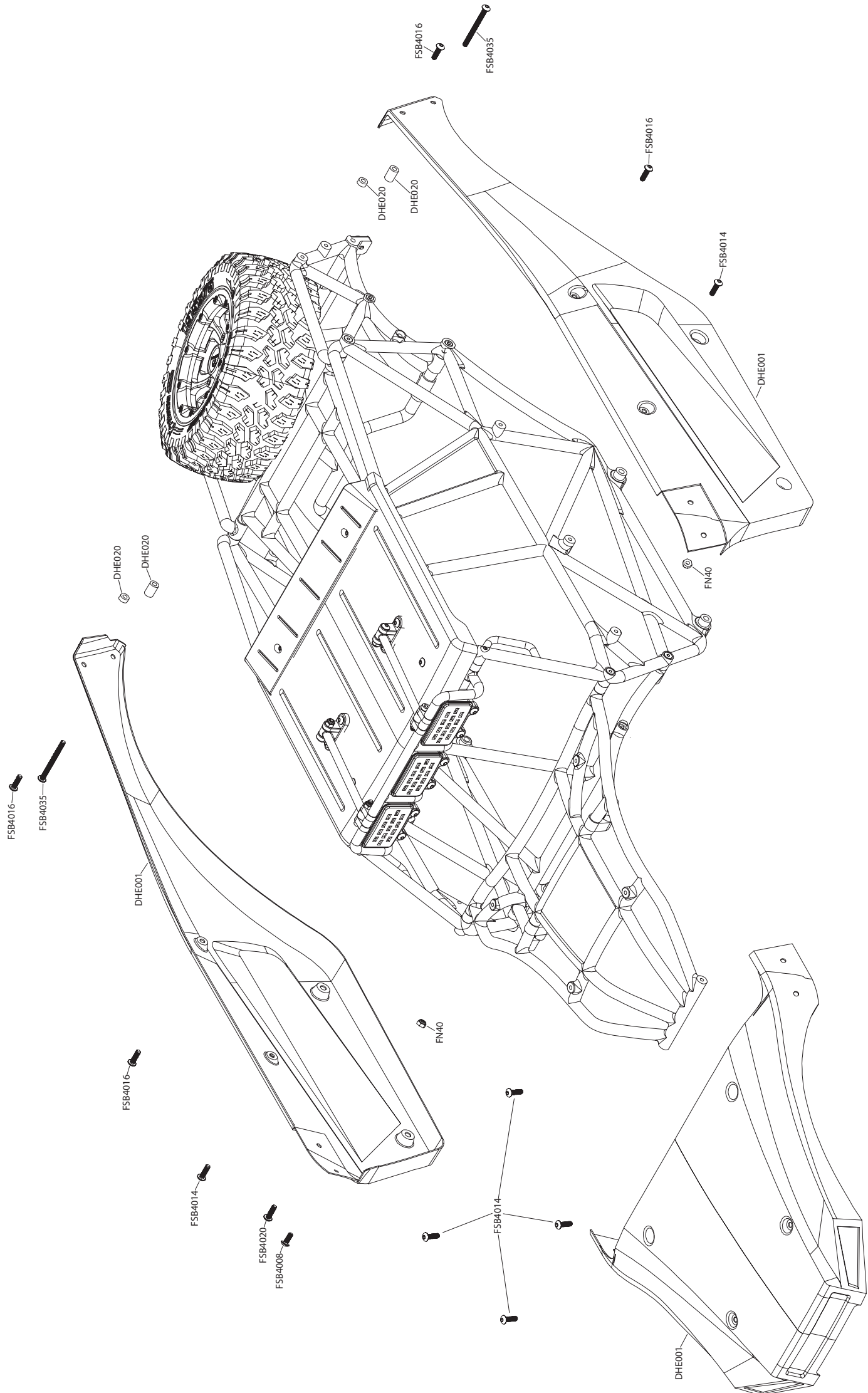

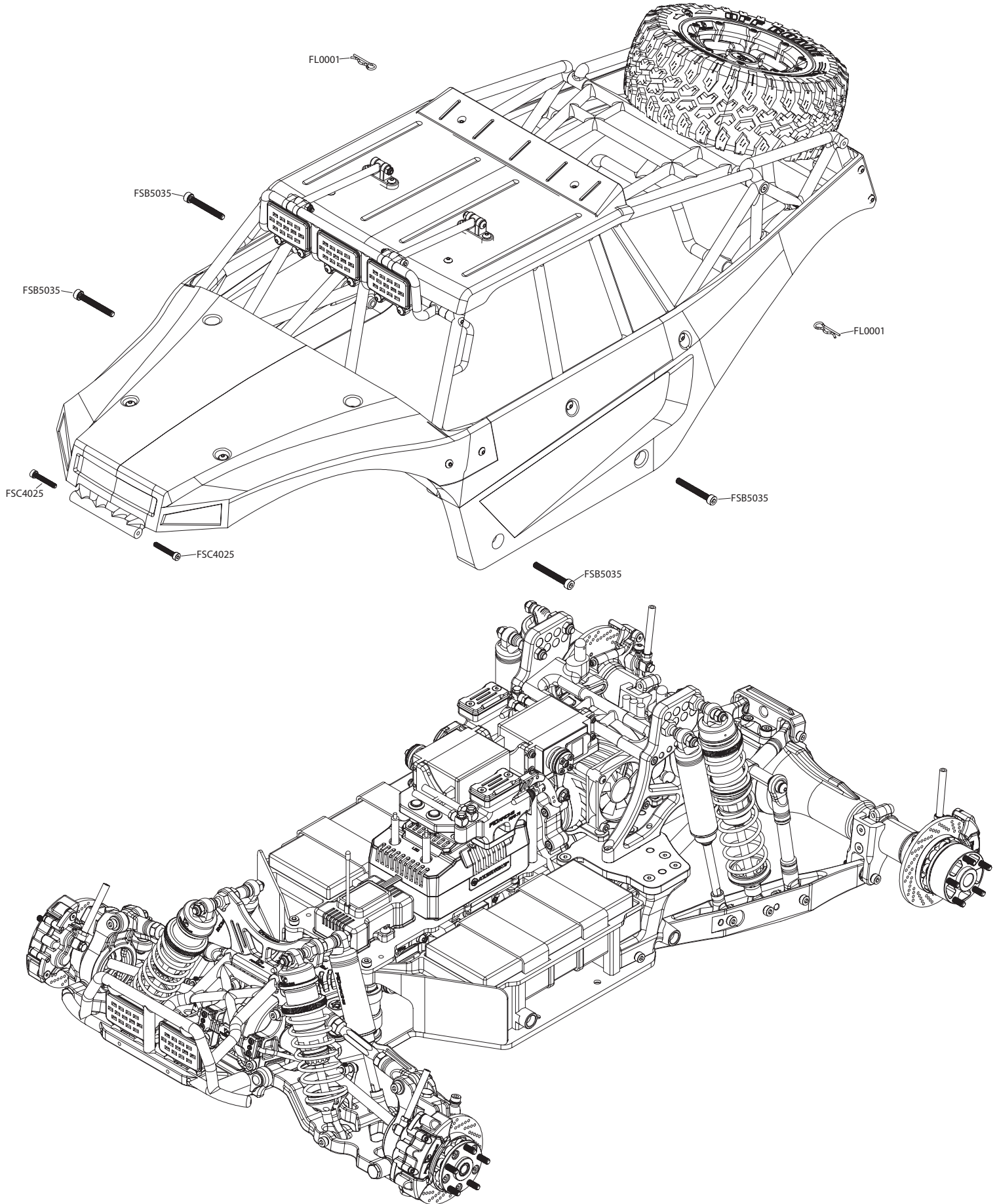

Wheel Installation

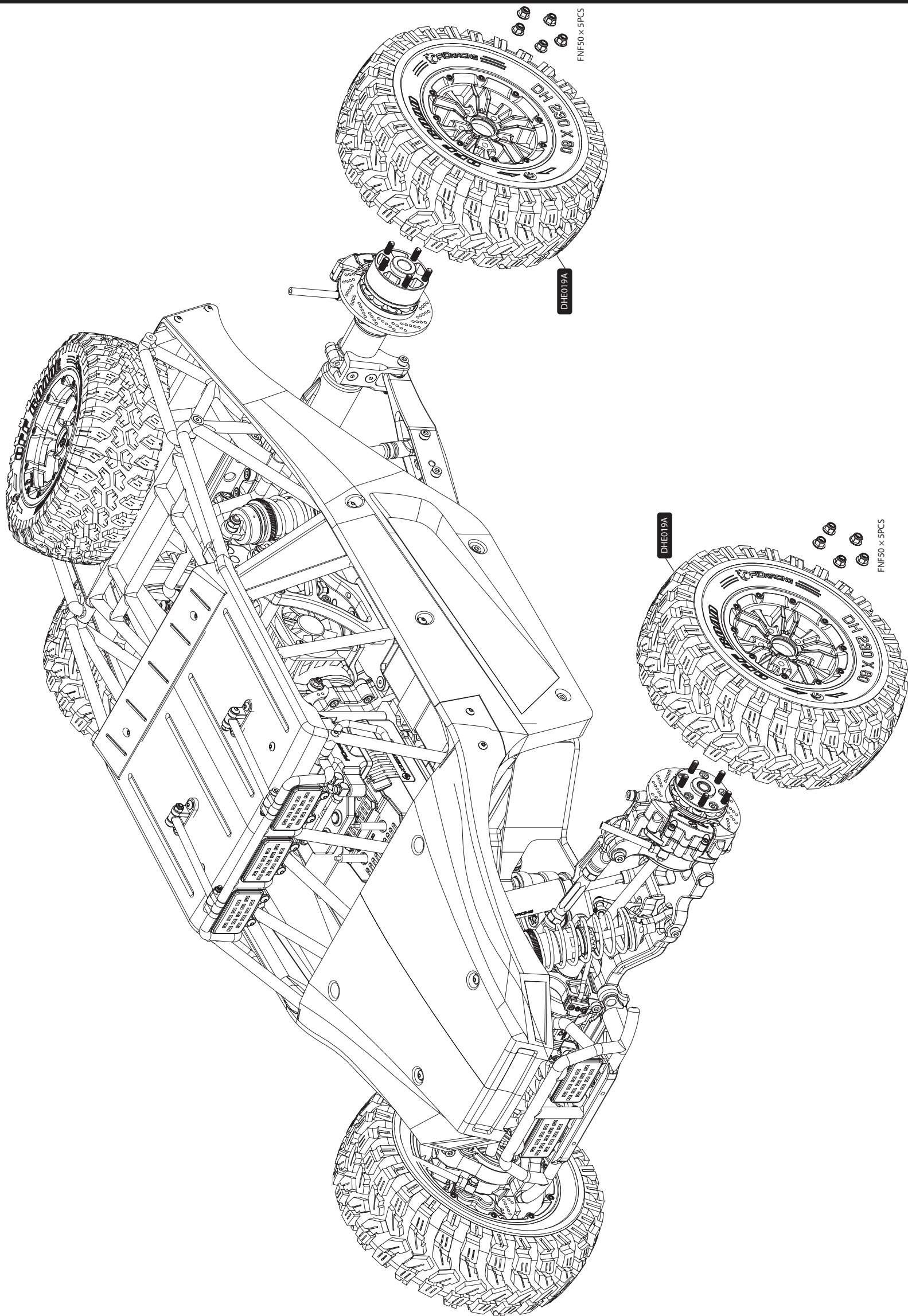

Assembly List

No.	Description	No.	Description
DHE001A	Front Uni Drive Shaft	DHE013A	Rear Uni Drive Shaft
DHE002A	Front Upper Arm	DHE014A	Trailing Arm
DHE003A	Front Shock Absorber	DHE015A	Rear Shock Absorber
DHE004A	Front Shock Damper	DHE016A	Rear Shock Damper
DHE005AL	Hydraulic Brake Caliper, Left	DHE017A	Rear Swaybar Lever
DHE005AR	Hydraulic Brake Caliper, Right	DHE018A	Master Cylinder
DHE006A	Front Diff	DHE019A	Wheel (230 × 80mm)
DHE007A	Central Diff	DHE020A	Spare Wheel (195 × 75mm)
DHE008A	Back Drive Shaft at Central Gearbox	DHE021A	Rear Solid Axle Setup
DHE009A	Steering Arm	DHE022A	Dual Servo Steering Setup
DHE010A	Steering Rod	DHE023A	Roll Cage
DHE011A	Rear Upper Link	DHE024A	Front Bumper
DHE012A	Rear Diff		

Part List

No.	Description	No.	Description
DHE001	Clear Body Set	DHE151	Center Gearbox - Rear
DHE002	Roll Cage Right	DHE152	Gear, 21T
DHE003	Roll Cage Left	DHE153	Gear, 60T
DHE004	Roll Cage Rear	DHE154	Gear Mount, 60T
DHE005	Roll Cage Front	DHE155	Center Diff Shaft
DHE006	Roll Cage Top	DHE156	Gearbox Cover
DHE007	Roll Cage Set	DHE157	18T Gear 6mm
DHE008	Roll Cage Set Front	DHE158	Front Shock Mount Bolt-A
DHE009	Roll Cage Set Right	DHE159	Front Shock Mount Bolt-B
DHE010	Roll Cage Set Left	DHE160	Motor Mount - Bottom
DHE011	Tail Lights Mount	DHE161	Motor Mount - Top
DHE012	Top Light Mount	DHE162	Fan Mount
DHE013	Top Light Bar	DHE163	Fan
DHE014	Top Light Mount Set	DHE164	Fan Mount Link
DHE015	Top Light Cover	DEH165	Front Drive Shaft Boot
DHE016	Top Light Pod	DHE166	Rear Top Plate
DHE017	Roll Cage Rear Set Left	DHE167	Rear Shock Tower
DHE018	Roll Cage Rear Set Right	DHE168	Rear Trailing Arm
DHE019	Link Bar Left	DHE169	Rear Trailing Arm Mount

No.	Description	No.	Description
DHE020	Link Bar Right	DHE170	Rear Upper Rod Mount - 1
DHE021	Tires (195 × 75mm)	DHE171	Rear Upper Rod Mount - 2
DHE022	Inner Foam (195 × 75mm)	DHE172	Rear Trailing Arm Mount - Left
DHE023	Wheel Barrel	DHE173	Rear Trailing Arm Mount - Right
DHE024	Outer Beadlock	DHE174	Rear Top Plate Support
DHE025	Inner Beadlock	DHE175	Rear Upper Rod Ball End
DHE026	Spare Tire Hub Cap	DHE176	Rear Upper Rod
DHE027	Spare Tire Mount - Bottom	DHE177	Spring Clip
DHE028	Spare Tire Mount - Top	DHE178	Washer 6 x 7.3mm
DHE029	Front Bumper	DHE179	Bearing Ø6 x Ø14 x 6mm
DHE030	Front Bumper Brace	DHE180	Rear Swaybar Mount
DHE031	Front Light Cover	DHE181	Rear Swaybar Turnbuckle
DHE032	Front Light Pod	DHE182	O-ring D15 x Ø4
DHE033	Pin Ø5 × 20mm	DHE183	Rear Swaybar Locker
DHE034	Front Gear Box Left	DHE184	Rear Swaybar
DHE035	Front Gear Box Right	DHE185	Bearing Ø9 x Ø17 x 4mm
DHE036	F/R Pinion Gear, 13T	DHE186	Roll Cage Mount
DHE037	Front Drive Shaft Joint	DHE187	Rear Shock Body
DHE038	Spring Locker	DHE188	Rear Hub Coupler-1
DHE039	Center Drive Shaft (220mm)	DHE189	Rear Hub Coupler-2
DHE040	Uni Hub Pin (Ø6.5mm)	DHE190	Rear Hub Coupler-3
DHE041	Pin Ø3.5 × 18mm	DHE191	Rear Shock & Damper Shaft
DHE042	Pin Ø4 × 20mm	DHE192	Brake Disc
DHE043	Pin Ø5 × 18mm	DHE193	Solid Axle Case - Rear
DHE044	Diff Cross Pin	DHE194	Solid Axle Case - Front
DHE045	Bearing Ø10 × Ø22 × 6mm	DHE195	Rear Drive Axle
DHE046	Bearing Ø10 × Ø26 × 8mm	DHE196	Rear Uni Yoke Joint
DHE047	Bearing Ø12 × Ø24 × 6mm	DHE197	Uni Hub
DHE048	Washer Ø21 × Ø27 × 1.5mm	DHE198	Uni Hub Pin
DHE049	Drive Cup	DHE199	O-ring D16 x Ø2.4
DHE050	Diff Cap	DHE200	Rear Uni Drive Shaft, Hollow
DHE051	Diff Gasket (44.9mm)	DHE201	Spline
DHE052	Diff Gasket (49mm)	DHE202	O-ring D20 x Ø2
DHE053	Diff Case	DHE203	O-ring D24 x Ø2.5
DHE054	Diff Ring Gear, 43T	DHE204	Front Damper Body
DHE055	Washer Ø9 × Ø22 × 0.3mm	DHE205	Damper Piston
DHE056	O-ring Ø9 × Ø15 × 3mm	DHE206	Spring Clip
DHE057	Diff Cross Pin Mount	DHE207	Damper Backup Ring

No.	Description	No.	Description
DHE058	Diff Bevel Planet Gear, 12T	DHE208	Aluminum Damper Seal Cap
DHE059	Diff Bevel Sun Gear, 16T	DHE209	Nylon Damper Seal Cap
DHE060	Tires (230 × 80mm)	DHE210	Front Damper Shaft
DHE061	Inner Foam (230 × 80mm)	DHE211	Rear Damper Body
DHE062	Front Hub Coupler-1	DHE213	Rear Short Shock Spring
DHE063	Front Hub Coupler-2	DHE214	Rear Shock Spring Divider
DHE064	Front Spindle Carrier	DHE215	Mount Post
DHE065	Front Lower Arm Right	DHE216	Pushrod
DHE066	Front Spindle Right	DHE217	Shock Boot
DHE067	Front Spindle Left	DHE218	Front Seal
DHE068	Front Lower Arm Left	DHE219	Piston
DHE069	Front Arm Hinge Pin Ø7 × 100mm	DHE220	Rear Seal
DHE070	Spindle Carrier Bolt	DHE221	Return Spring
DHE071	Kingpin Bolt	DHE222	Filler Cap
DHE072	Bearing Ø12 × Ø28 × 8mm	DHE223	Gasket
DHE073	Bearing Ø20 × Ø32 × 7mm	DHE224	Oil Reservoir & Master Cylinder
DHE074	Uni Stub Axle	DHE225	Master Cylinder Mount
DHE075	Uni Drive Shaft (153.5mm)	DHE226	Oil Tube
DHE076	Pin Ø8 × 16mm	DHE227	Washer
DHE077	Pin Ø5 × 20mm	DHE228	Connector
DHE078	Front Shock Shaft	DHE229	Coupler
DHE079	Pin Ø5 × 25mm	DHE230	Bolt
DHE080	Spring Locker	DHE231	Braking System Mount
DHE081	Front Damper Shaft	DHE232	Switch
DHE082	Front Gearbox Mount - Upper	DHE233	Brake Servo
DHE083	Front Gearbox Mount - Lower	DHE234	Brake Pedal
DHE084	Front Top Plate	DHE235	Brake Pad
DHE085	Front Shock Tower	DHE236	Caliper body
DHE086	Front Bumper Brace Mount	DHE237	Bridge
DHE087	Swaybar Stay	DHE238	Sliding Pin Boot
DHE088	Hinge Pin Cover - Front	DHE239	Sliding Pin
DHE089	Hinge Pin Cover - Rear	DHE240	Piston
DHE090	Swaybar Lever	DHE241	Bolt M4 × 10
DHE091	Ball 6.5 × 7mm	DHE242	Cylinder Body Left
DHE092	Ball 6.5 × 17mm	DHE243	Cylinder Body Right
DHE093	Front Swaybar	FSB4008	Button Head Screw M4×8 (4 pcs)
DHE094	Chassis	FSB4012	Button Head Screw M4×12 (6 pcs)
DHE095	Ball End	FSB4014	Button Head Screw M4×14 (16 pcs)

No.	Description	No.	Description
DHE096	Nut Set, M8	FSB4016	Button Head Screw M4×16 (8 pcs)
DHE097	Front Upper Arm Turnbuckle	FSB4018	Button Head Screw M4×18 (2 pcs)
DHE098	Steering Turnbuckle	FSB4020	Button Head Screw M4×20 (4 pcs)
DHE099	Steering Drag Linkage	FSB4025	Button Head Screw M4×25 (11 pcs)
DHE100	Flange Bushing	FSB4030	Button Head Screw M4×30 (8 pcs)
DHE101	Steering Horn B	FSB4035	Button Head Screw M4×35 (2 pcs)
DHE102	Steering Horn A	FSB5012	Button Head Screw M5×12 (2 pcs)
DHE103	Steering Horn C	FSB5016	Button Head Screw M5×16 (2 pcs)
DHE104	Steering Tube	FSB5020	Button Head Screw M5×20 (2 pcs)
DHE105	Steering Spring Adjust Ring	FSB5030	Button Head Screw M5×30 (2 pcs)
DHE106	Steering Post	FSB5035	Button Head Screw M5×35 (4 pcs)
DHE107	Steering Torsion Spring	FSF4012	Flat Head Screw M4×12 (32 pcs)
DHE108	Bearing Ø7 × Ø14 × 5mm	FSF4030	Flat Head Screw M4×30 (4 pcs)
DHE109	Flange Bearing Ø7 × Ø13 × Ø14 × 4mm	FSF4035	Flat Head Screw M4×35 (2 pcs)
DHE110	Ball 9 x 10.8mm	FSF5012	Flat Head Screw M5×12 (2 pcs)
DHE111	Ball 11 x 13mm	FSF5016	Flat Head Screw M5×16 (54 pcs)
DHE112	Ball 11 x 15mm	FSF5020	Flat Head Screw M5×20 (14 pcs)
DHE113	Rear Shock Mount Bolt	FSF5035	Flat Head Screw M5×35 (2 pcs)
DHE114	Front Shock Body	FSF6016	Flat Head Screw M6×16 (4 pcs)
DHE115	Shock Top End	FSC3008	Cup Head Screw M3×8 (35 pcs)
DHE116	Spring Torsion Adjuster	FSC3010	Cup Head Screw M3×10 (4 pcs)
DHE117	Shock Spring Perch	FSC3012	Cup Head Screw M3×12 (12 pcs)
DHE118	F/R Shock Long Spring	FSC3016	Cup Head Screw M3×16 (8 pcs)
DHE119	Nylon Shock Seal Cap	FSC3035	Cup Head Screw M3×35 (4 pcs)
DHE120	Front Shock Shaft	FSC4010	Cup Head Screw M4×10 (4 pcs)
DHE121	Shock Shaft End	FSC4012	Cup Head Screw M4×12 (4 pcs)
DHE122	Plastic Bushing	FSC4014	Cup Head Screw M4×14 (10 pcs)
DHE123	Ball 11 x 13mm	FSC4016	Cup Head Screw M4×16 (25 pcs)
DHE124	Aluminum Shock Seal Cap	FSC4020	Cup Head Screw M4×20 (12 pcs)
DHE125	Shock Piston	FSC4025	Cup Head Screw M4×25 (6 pcs)
DHE126	Shock Backup Ring	FSC4035	Cup Head Screw M4×35 (3 pcs)
DHE127	Shock Shaft Guide	FSC4040	Cup Head Screw M4×40 (2 pcs)
DHE128	Shock Diaphragm	FSC4075	Cup Head Screw M4×75 (2 pcs)
DHE129	O-ring D14 x Ø3	FSC5012	Cup Head Screw M5×12 (8 pcs)
DHE130	O-ring D21 x Ø2	FSC5014	Cup Head Screw M5×14 (2 pcs)
DHE131	O-ring D33 x Ø2.5	FSC5016	Cup Head Screw M5×16 (16 pcs)
DHE132	Steering Servo	FSC5020	Cup Head Screw M5×20 (13 pcs)
DHE133	Servo Arm Lock	FSC5025	Cup Head Screw M5×25 (4 pcs)

No.	Description	No.	Description
DHE134	Servo Arm	FSC5030	Cup Head Screw M5×30 (14 pcs)
DHE135	Servo Arm Mount	FSC5035	Cup Head Screw M5×35 (22 pcs)
DHE136	Servo Arm Link	FMS4004	Set Screw M4×4 (2 pcs)
DHE137	Servo Arm Link Bolt	FMS4005	Set Screw M4×5 (6 pcs)
DHE138	Ball 9 x 19mm	FMS5010	Set Screw M5×10 (2 pcs)
DHE139	Servo Turnbuckle	FMS6005	Set Screw M6×5 (4 pcs)
DHE140	Servo Turnbuckle Ball End	FMS6008	Set Screw M6×8 (7 pcs)
DHE141	Servo Mount	FW030810	Washer Ø3×Ø8×1 (8 pcs)
DHE142	Battery Box - Left	FW051010	Washer Ø5×Ø10×1 (2 pcs)
DHE143	Battery Box - Right	FW061308	Washer Ø6×Ø13×0.8 (2 pcs)
DHE144	Receiver Cover	FW061310	Washer Ø6×Ø13×1 (6 pcs)
DHE145	ESC Mount	FNF50	Nut M5 (24 pcs)
DHE146	Antenna Tube	FN40	Nut M4 (18 pcs)
DHE147	Velcro Tape	FN50	Nut M5 (6 pcs)
DHE148	Motor	FN60	Nut M6 (16 pcs)
DHE149	ESC	FSS3018	Tap Screw M3×18 (80 pcs)
DHE150	Center Gearbox - Front		



Since being founded in Oct 2010, FID Racing strives to bring the best car to the market, sophisticated as well as playful, robust. Our manufacture are mainly done with numerical controlled equipment. Each product is tested before delivery.

Follow us on

Web: www.fid-racing.com

Youtube: [@fid_racing](https://www.youtube.com/@fid_racing)

Facebook: [@fidracing](https://www.facebook.com/fidracing)

Tiktok: [@fidracing](https://www.tiktok.com/@fidracing)